



# More Precision

**optoCONTROL** // Optical precision micrometers





	Measuring range 28mm
	Resolution typ. 2µm
	Repeatability typ. ±4µm
	Analogue output 0 ... 10VDC
	Serial interface RS232
	Laser class 1

- ▶ Visible laser line (red light 670nm)
- ▶ Working distance of up to 2,000mm
- ▶ Integrated interference filter
- ▶ CCD line detector with 2,048 pixels, 16,384 sub-pixels (8-fold)
- ▶ 2 digital inputs, 2 digital outputs
- ▶ Robust aluminium housing suitable for industrial use

Measurement mode (programmable via software)

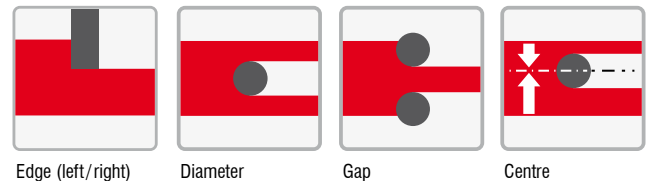

Edge (left/right)

Diameter

Gap

Centre

### Measuring principle

The laser beam for the optoCONTROL 1220 laser micrometers is output from the optical transmitter as a parallel aimed laser beam. The laser line strikes a CCD array in the receiving optical system. The amount of light collected by each of these receiving elements during the integration time is read out separately as analogue voltage and stored as a digital value in a data field after analogue-to-digital conversion. If there is a non-transparent measurement object in the laser line, only the receiving elements of the lines outside the shadow zone of the measurement object are illuminated. As the spacing of the pixels of the CCD array is known, the size and position of the measurement object can be determined.

### System design

optoCONTROL 1220 series is specifically designed for measuring edges, diameters and gaps of up to 2,000mm. The laser micrometer consists of a light source and a receiving unit. The complete controller electronics are integrated in the receiver housing. The light source and receiver can be installed at any distance from each other. All models can be installed without additional brackets in both vertical and horizontal positions.

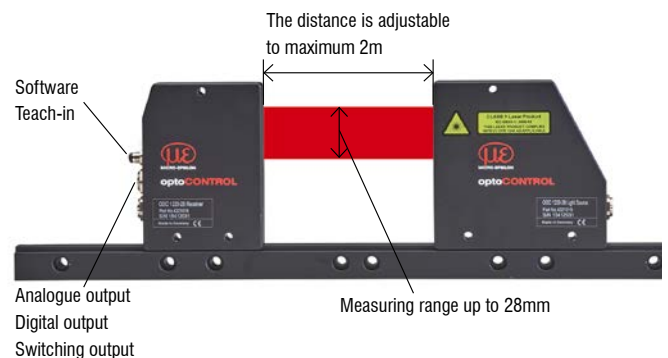

Model	ODC1220-28
Measuring range	typ. 28mm
Distance light source - receiver	min. 20mm to max. 2000mm
Resolution	typ. 2µm
Repeatability <sup>1)</sup>	typ. ±4µm
Linearity <sup>2)</sup>	typ. ±0.08% [typ. ±22µm]
Measuring rate	max. 200Hz
Max. switching current	100mA, short-circuit proof
Interface	Measurement values via RS232, parametrizable under Windows using the ODC1202 tool (included in scope of supply)
Laser	semiconductor laser, 670nm, DC-operation, ≤0.39mW max. opt. power, laser class 1 <sup>3)</sup> the use of these laser sensors therefore requires no additional protective measures
Optical filter	interference filter, RG645; polarisation filter
Housing material	aluminium, anodised in black
Connector receiver	8-pin female connector type binder series 712 (SPS/Power); 4-pin M5 female connector type binder series 707 (RS232/PC)
Connector light source	4-pin female connector type binder 712 (connection to receiver))
Connection cable	connection to PC: SCD1202 (RS232) or SCD12xx (USB version incl. driver) Power and connection to SPS: SCA1202; connection cable light source/receiver: CE1220
Output polarity	bright/dark-switching, adjustable using Windows
LED-indication	LED red (+) : measured value > upper tolerance threshold; LED green : measured value lies within tolerance window LED red (-) : measured value < lower tolerance threshold; LED yellow : Power-LED (multifunction)
EMC	IEC 60947-5-2
Protection class	electronics: IP54, optics: IP67
Operation temperature range	-10°C ... +50°C
Storage temperature range	-20°C ... +85°C
Analogue output (ANA)	1x voltage output 0 ... +10V (scalable)
Digital outputs (OUT0, OUT1)	OUT0: (-) measured value < lower tolerance threshold; OUT1: (+) measured value > upper tolerance threshold pnp bright-switching/npn dark-switching or pnp dark-switching/npn bright-switching, adjustable using Windows®, 100mA, short-circuit proof
Digital inputs (IN0, IN1)	IN0: external trigger, IN1: teach/reset (double function); input voltage +Ub/0V with protective circuit
Power supply	+24VDC (± 10%)
Sensitivity adjustment	using Windows® via PC (parameterization software included)
Laser adjustment	adjustable under Windows® via PC
Consumption	typ. 200mA
Mounting rail	ODC1220-L220/L420/L620 (max. distance light source - receiver ≤ 220/420/620mm)

All specifications are measured at a constant temperature of 20 °C after a warm-up time of 30 minutes.

<sup>1)</sup> Valid for ΔT ≤ 5°C and ambient light 5000lx. For stable measurement shadowing of the receiver is advisable. Smooth video AVG 64 values.

<sup>2)</sup> Is only valid with the adaption of the threshold and the laser performance as well as the execution of an calibration; 20mm target-receiver distance; 250mm transmitter-receiver distance

<sup>3)</sup> Laser class 1: IEC 60825-1: 2008-05

ODC1220-28-T (light source)

ODC1220-28-R (receiver)

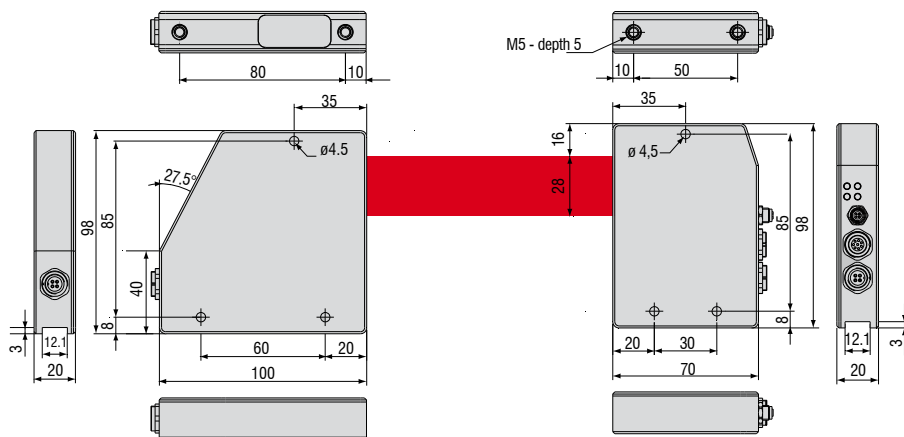

Mounting rail ODC1220-L220/L420/L620

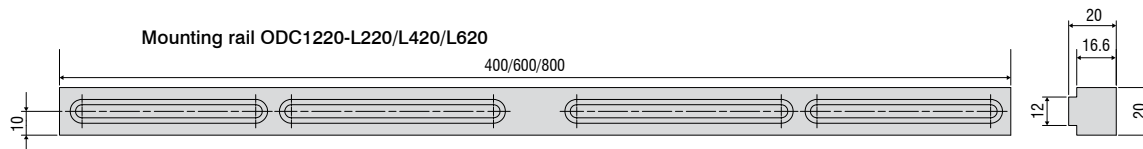

### IF2008 - PCI interface card

#### Particular benefits

- 4x digital signals and two encoders with basic printed circuit board
- Additional expansion board for a total of 6x digital signals, 2x encoder and 2x analogue signals and 8x I/O Signals
- FIFO data memory
- Synchronous data acquisition



Example: measurement of diameters with two optoCONTROL. The diameter to be measured can be increased using two optoCONTROL. See CSP2008 universal controller.

### IF2008E - Expansion board

#### Particular benefits

- Two digital signals, two analogue signals and 8 I/O signals
- Overall with IF2008: 6 digital signals, 2 encoders and 2 analogue signals and 8 I/O signals
- FIFO data memory
- Synchronous data acquisition



### Diverse ODC tools

Depending on the sensor, diverse tools for continuous measurement value recording and parameter set up are available free of charge.

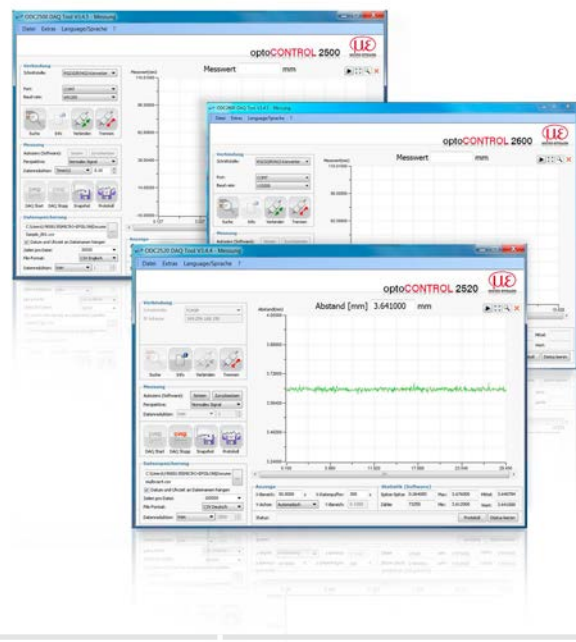

### CSP2008 - Universal controller for up to six sensor signals

The controller CSP2008 has been designed to process 2 to 6 both optical and other sensors from Micro-Epsilon (6 digital or 4 analogue input signals max., 2x internal + 4x external via EtherCAT modules from the company Beckhoff. EtherCAT is intended as external bus for connecting further sensors and I/O modules. The controller is equipped with a display offering multicolour backlighting which changes its colour in the case of exceeding the limit value while a signal is displayed.

#### Features

- Real-time processing of input and output signals at up to 100kHz (user selectable)
- Unique user interface for the configuration of the controller via Ethernet on a PC or laptop. All user selectable functions of the controller and the measured values can be viewed, displayed and stored in real time via your own web browser without installing any 3rd part software
- Simple sensor connection with automatic sensor recognition, configuration of the sensor using buttons and display on controller or via web browser
- Modular system upgradable with additional I/O modules for customer-specific requirements. The internal communication between I/O components using EtherCAT connection (CSP 2008 acts as master)
- Extremely flexible and powerful functionality; function modules can be combined in many ways.
- Simple mounting using DIN rail TS 35

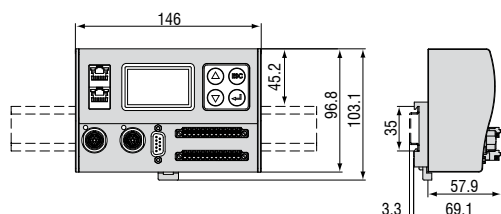

Universal controller with DIN rail TS 35  
(dimensions not to scale)

### IF1032/ETH

The IF1032/ETH interface module now enables to run sensors equipped with analogue interfaces with the proven operating concept based on a web interface. The Ethernet interface permits to easily display the measured data on a PC. Moreover, sensors can be connected to an EtherCAT bus. The RS485 interface allows to connect new sensors that use the Micro-Epsilon specific RS485 protocol.

#### Interfaces

- 1x RS485 (ME-internal protocol)
- 2x analogue-in (14 bit, max. 4 ksps), voltage
- 1x analogue-in, (14 bit, max. 4 ksps), current
- Inputs for supply voltage
- Trigger input
- EtherCAT synchronisation output
- Output for sensor power supply



**Accessories optoCONTROL 1200/1201**

Article number	Model	Description
2901260	PC1200-5	Power supply and signal cable 5m, straight connector, for light source and receiver unit
2901483	PC1200-10	Power supply and signal cable 10m, straight connector, for light source and receiver unit
2901261	PC1200/90-5	Power supply and signal cable 5m, angled connector, for light source and receiver unit
0260031.11	DD241PC(11)-U	Digital display unit, RS232, connection for 1 analogue sensor 0-10V, 2 limit switches
2420066	IF1032/ETH	ME Ethernet/EtherCAT interface module max.14Bit/4k samples/sec
2966006 *	ODC1202-L100	Mounting rail for ODC1202, 400mm; distance light source/receiver max.100mm
2966007 *	ODC1202-L200	Mounting rail for ODC1202, 500mm; distance light source/receiver max. 200mm
2966008 *	ODC1202-L500	Mounting rail for ODC1202, 800mm; distance light source/receiver max. 500mm
2966018	JU1200-VR	ODC1200 adjustment plate for vertical mounting of the receiver
2966019	JU1200-HR	ODC1200 adjustment plate for horizontal mounting of the receiver
2966020	JU1200-VT	ODC1200 adjustment plate for vertical mounting of the transmitter
2966021	JU1200-HT	ODC1200 adjustment plate for horizontal mounting of the transmitter
2966024	BR1200L220	Bracket for mounting as C-frame, length 220mm, 2 pcs. required
2966025	BR1200L320	Bracket four mounting as C-frame, height 320mm, 2 pcs. required

\*only for C-frame mounting combined with adjustment plate JU1200 and bracket BR1200

**Accessories optoCONTROL 1202**

2901497	CE1202-2	Connecting cable light source-receiver, 2m
2901482	CE1202-5	Connecting cable light source-receiver, 5m
2901371	SCD1202-2-RS232	Digital output cable, 2m, for connection to a RS232 port
2901509	SCD1202-5-RS232	Digital output cable, 5m, for connection to a RS232 port
2901848	SCD12xx-2-USB	Digital output cable for USB connection incl. driver, 2m
2901373	SCA1202-2	Power supply and analogue output cable, 2m
2901510	SCA1202-5	Power supply and analogue output cable, 5m
2966006	ODC1202-L100	Mounting rail for ODC1202, 400mm; distance light source/receiver max.100mm
2966007	ODC1202-L200	Mounting rail for ODC1202, 500mm; distance light source/receiver max. 200mm
2966008	ODC1202-L500	Mounting rail for ODC1202, 800mm; distance light source/receiver max. 500mm
6414114	EK1100/CSP2008	Bus terminal
6414107	EL3162/CSP2008	Bus terminal; 2-channel analogue input terminal
2420057	CSP2008	Universal controller for displacement sensors
2420066	IF1032/ETH	ME Ethernet/EtherCAT interface module max.14Bit/4k samples/sec

**Accessories optoCONTROL 1220**

2901871	CE1220-1	Connecting cable light source-receiver, 1m
2901851	CE1220-2	Connecting cable light source-receiver, 2m
2901852	CE1220-5	Connecting cable light source-receiver, 5m
2901371	SCD1202-2-RS232	Digital output cable, 2m, for connection to a RS232 port
2901509	SCD1202-5-RS232	Digital output cable, 5m, for connection to a RS232 port
2901848	SCD12xx-2-USB	Digital output cable for USB connection incl. driver, 2m
2901373	SCA1202-2	Power supply and analogue output cable, 2m
2901510	SCA1202-5	Power supply and analogue output cable, 5m
2966009	ODC1220-L220	Mounting rail for ODC1220, 400mm; distance light source/receiver max. 220mm
2966011	ODC1220-L420	Mounting rail for ODC1220; 600mm; distance light source/receiver max. 420mm
2966012	ODC1220-L620	Mounting rail for ODC1220; 800mm; distance light source/receiver max. 620mm
6414114	EK1100/CSP2008	Bus terminal
6414107	EL3162/CSP2008	Bus terminal; 2-channel analogue input terminal
2420057	CSP2008	Universal controller for displacement sensors
2420066	IF1032/ETH	ME Ethernet/EtherCAT interface module max.14Bit/4k samples/sec

**Accessories optoCONTROL 2500/2600**

2901123	PC2500-3	Power supply cable 3m, open
2901124	PC2500-10	Power supply cable 10m, open
2901120	SCA2500-3	Signal output cable, analogue, 3m
2901215	SCA2500-10	Signal output cable, analogue, 10m
2901121	SCD2500-3/3/RS232	Signal output cable, 3m, analogue / RS232
2213017	IF2008	PCI interface card RS422
2213018	IF2008E	Expansion board analogue / RS422 / PCI
2901122	SCD2500-3/10/RS422	Signal output cable, 3m, analogue / RS422, 10m
2901057	CE1800-3	Sensor cable extension for camera, 3m
2901118	CE2500-3	Sensor cable extension for light source, 3m
2901058	CE1800-8	Sensor cable extension for camera, 8m
2901119	CE2500-8	Sensor cable extension for light source, 8m
2420057	CSP2008	Universal controller for up to six sensor signals
2901504	SCD2500-3/CSP	Output cable, 3m, for connection to CSP2008
2901505	SCD2500-10/CSP	Output cable, 10m, for connection to CSP2008

**Accessories optoCONTROL 2500/2600**

2964022	MBC300	Assembly block for controller ODC2500/2600
2213024	IF2004/USB converter	4 channel RS422/USB converter
2213025	IF2001/USB converter	IF2001/USB converter RS422 to USB
2213022	RS-422/USB converter	Industrial converter for ODC2xxx sensors, RS-422/USB
29011111	SCD2500-3/RS422	Output cable RS422, 3m, open ends
2901528	IF2008-Y adaptation cable	Adaptation cable, Y-type, 100mm
2901561	SCD2500-3/IF2008	Interface cable
2901563	SCD2500-8/IF2008	Interface cable
6414071	Extension clamp	Extension clamp RS422 to CSP2008

**Accessories optoCONTROL 2520**

2901925	SCD2520-3	Digital output cable, 3m, RJ45/ Ethernet/EtherCAT
29011002	SCD2520/90-5	Digital output cable, 5m, RJ45/ Ethernet/EtherCAT
29011042	SCD2520/90-8	Digital output cable, 8m, RJ45/ Ethernet/EtherCAT
29011003	PC/SC2520/90-5	Supply-, interface- and signal cable, 5m
2901918	PC/SC2520-3	Supply-, interface- and signal cable, 3m
29011037	PC/SC2520-10	Supply-, interface- and signal cable, 10m
29011038	PC/SC2520-20	Supply-, interface- and signal cable, 20m
29011039	PC/SC2520-30	Supply-, interface- and signal cable, 30m
29011040	SCD2520-5 M12	Digital output cable Ethernet/EtherCAT, 5m
2901919	CE2520-1	Connecting cable light source-receiver, 1m
2901920	CE2520-2	Connecting cable light source-receiver, 2m
2901921	CE2520-5	Connecting cable light source-receiver, 5m
2901922	CE2520/90-1	Connecting cable light source-receiver, 1m
2901923	CE2520/90-2	Connecting cable light source-receiver, 2m
2901924	CE2520/90-5	Connecting cable light source-receiver, 5m
2901967	PC/SC2520-3/CSP	Interface and supply cable for CSP2008
29011014	PC/SC2520-3/IF2008	Interface and supply cable for IF2008
2213024	IF2004/USB converter	4 channel RS422/USB converter
2213022	RS-422/USB converter	Industrial converter for ODC2xxx sensors, RS-422/USB
2213025	IF2001/USB converter	Single channel RS422/USB converter
0260031.10	DD241PC(10)-U	Digital process display, 0...10V
0260031.11	DD241PC(11)-U	Digital process display, 2 limit switches, 0...10V
2213017	IF2008	PCI interface card RS422
2213018	IF2008E	Expansion board analogue / RS422 / PCI
2901528	IF2008-Y adaptation cable	Adaptation cable, Y-type, 100mm
2420057	CSP2008	Universal controller for displacement sensors
6414071	Extension clamp	Extension clamp RS422 to CSP2008
6414113	EK1122/CSP2008	2 port RJ45 EtherCAT junction
6414114	EK1100/CSP2008	Bus terminal

**Accessories power supplies**

2420065	PS2030	Wall power supply 24V/24W/ 1A; 2m-PVC; clamp
2420062	PS2020	Power supply for DIN rail mounting 24VDC / 2.5A
2420042	PS2011	Power supply for laboratory use 230VAC/ 24VDC / 5.2A

Further cable lengths on request.



Laser radiation  
Do not view directly with  
optical instruments  
Class 1M Laser Product  
IEC 60825-1: 2008-05  
 $P \leq 2\text{mW}$ ,  $E \leq 0.2\text{mW/cm}^2$ ;  $\lambda = 670\text{nm}$

optoCONTROL 2520 use a semiconductor class 1M laser with a wavelength of 670nm. The maximum optical output power is  $\leq 2\text{mW}$ . This laser class does not require any additional protection equipment. Be careful with the dazzling effect related to optical instruments.



Class 1 Laser Product  
IEC 60825-1: 2008-05

optoCONTROL 12xx and 2500 use a semiconductor class 1 laser with a wavelength of 670nm. The maximum optical output power is  $\leq 0.39\text{mW}$ . This laser class does not require any additional protection equipment.

## High performance sensors made by Micro-Epsilon



Sensors and systems for displacement and position



Sensors and measurement devices for non-contact temperature measurement



2D/3D profile sensors (laser scanner)



Optical micrometers, fibre optic sensors and fibre optics



Colour recognition sensors, LED analyzers and colour online spectrometer

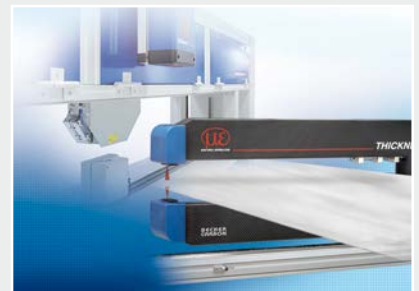

Measurement and inspection systems